

Owner's Guide and Installation Instructions



Electric Domestic Water Heater



*This water heater must be installed and serviced by a qualified person.
Please leave this guide with the householder.*

PATENTS

This water heater may be protected by one or more patents or registered designs in the name of Rheem Australia Pty Ltd.

TRADEMARKS

® Registered trademark of Rheem Australia Pty Ltd.
TM Trademark of Rheem Australia Pty Ltd.

Note: Every care has been taken to ensure the accuracy in preparation of this publication. No liability can be accepted for any consequences, which may arise as a result of its application.

CONTENTS

HOUSEHOLDER - We recommend you read pages 4 to 20.

The other pages are intended for the installer
but may be of interest

About Your Water Heater	4
Maintenance Requirements	10
Water Supplies	14
Save A Service Call	18
Installation	21
Connections – Plumbing	32
Connections – Electrical	37
Commissioning	39
Draining The Water Heater	42
Warranty	45

ABOUT YOUR WATER HEATER

WATER HEATER APPLICATION

This water heater is designed for use in a single family domestic dwelling for the purpose of heating potable water. Its use in an application other than this may shorten its life.

MODEL TYPE

The Rheem® water heater you have chosen is either a Rheemglas® or a RheemPlus™ model.

Rheemglas models are available with either a single heating unit or with twin heating units and RheemPlus models are available with a single heating unit only (refer to “Single Element Model” on page 7 and “Twin Element Model” on page 7). The water heater is suitable for either indoor or outdoor installation, except a water heater supplied with a power supply cord and plug is suitable for indoor installation only.

Water is stored in a vitreous enamel lined steel cylinder and heated by the electric immersion heating unit. The thermostat controls the temperature. Automatic safety controls are fitted to the water heater to provide safe and efficient operation.

Depending on the model of water heater, it may have caps or brass plugs on one side of the tank. The plugs and caps block off alternative connection points and are not to be tampered with or removed.

HOW HOT SHOULD THE WATER BE?

The water heater features an adjustable thermostat, which allows you to choose the most suitable temperature for your hot water needs. Refer to “Temperature Adjustment” on page 5.

A RheemPlus water heater is temperature limited to deliver water not exceeding 50°C.

To meet the requirements of the National Plumbing Standard the temperature of the stored water must not be below 60°C.

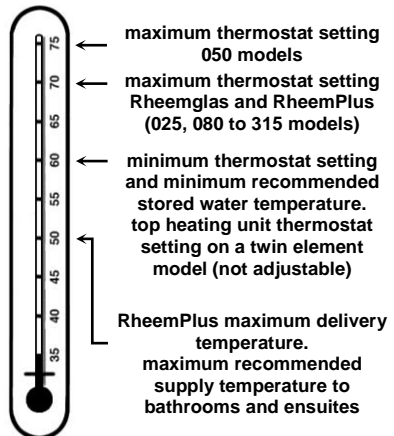

HOTTER WATER INCREASES THE RISK OF SCALD INJURY

This water heater can deliver water at temperatures which can cause scalding. Check the water temperature before use, such as when entering a shower or filling a bath or basin, to ensure it is suitable for the application and will not cause scald injury.

We recommend and it may also be required by regulations that an approved temperature limiting device be fitted into the hot water pipe work to the bathroom and ensuite when a Rheemglas water heater is installed. This will keep the water temperature below 50°C at the bathroom and ensuite. The risk of scald injury will be reduced and still allow hotter water to the kitchen and laundry.

A RheemPlus water heater will not deliver temperatures exceeding 50°C, in accordance with AS 3498. There is no need to fit a temperature limiting device to satisfy the requirements of AS/NZS 3500.4, if a RheemPlus water heater is installed in an application where 50°C is the maximum permissible hot water temperature at the outlet of a sanitary fixture used primarily for personal hygiene purposes.

THERMOSTAT

The thermostat automatically controls the electricity supply to the heating unit so a constant temperature is maintained. The thermostat and its protective over temperature cut out is mounted inside the front cover of the water heater. There is no need to switch the water heater off when it is not in use, except when you are on an extended holiday. The thermostat is fully automatic and power is only used when heating is required.

TEMPERATURE ADJUSTMENT

A Rheemglas or RheemPlus water heater features a tradesperson adjustable thermostat. This requires a licensed tradesperson to make any temperature adjustments. The thermostat (bottom thermostat on twin element models) has a maximum temperature setting of 70°C (75°C for 050 models) and a minimum temperature setting is 60°C. The top thermostat on a twin element model has a fixed setting of 60°C and cannot be adjusted.

We advise you have your electrician adjust the thermostat to the lowest temperature setting that meets your needs, especially if there are young children or elderly people in your home. Refer to **“Hotter Water Increases The Risk of Scald Injury”** on page 5.

A RheemPlus water heater is temperature limited to 50°C at the hot water outlet. The minimum thermostat setting should be 65°C to assist in the specified operation of its temperature limiting device. Increasing the thermostat setting will not increase the outlet temperature but will provide more hot water capacity.

SAFETY

This water heater is supplied with a thermostat, an over-temperature cut-out, and a combination temperature pressure relief valve. In addition, a RheemPlus water heater has a temperature limiting valve. These devices must not be tampered with or removed. The water heater must not be operated unless each of these devices is fitted and is in working order.

The operation of the over-temperature cut-out on the thermostat indicates a possibly dangerous situation. If the over-temperature cut-out operates, it must not be reset and the water heater must be serviced by a qualified person.

If the power supply cord, plug or electrical conduit to the water heater is damaged, it must be replaced by a qualified person in order to avoid a hazard. The power supply cord and plug must be replaced with a genuine replacement part available from Rheem. Phone Rheem Service or their nearest Accredited Service Agent to arrange for an inspection.

The Rheem warranty may not cover faults if relief valves or other safety devices are tampered with or if the installation is not in accordance with these instructions.

WARNINGS

- This water heater is only intended to be operated by persons who have the experience or the knowledge and the capabilities to do so.
- This water heater is not intended to be operated by persons with reduced physical, sensory or mental capabilities i.e. the infirm, or by children. Children should be supervised to ensure they do not interfere with the water heater.
- This water heater uses 240 V AC power for the electrically operated components. The removal of the front cover(s) will expose 240 V wiring. It must only be removed by a qualified person.
- Take care not to touch the power plug on a water heater fitted with a power supply cord and plug with wet hands.
- For continued safety of this water heater it must be installed, operated and maintained in accordance with the Owner's Guide and Installation Instructions.

SINGLE ELEMENT MODEL

This type of water heater has one heating unit with its own thermostat, located at the base of the water heater.

- **Continuous electricity supply**
This type of connection is suited to where the storage capacity is less than the normal daily usage.
- **Off-Peak electricity supply**
This type of connection will only allow heating to occur during set hours. A volume of water sufficient for the day's total use is heated and stored. This type of heating will be more economical due to reduced tariffs by the electricity authority.

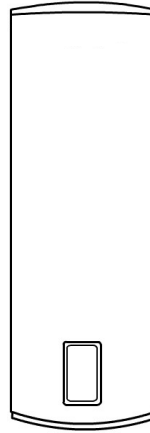

TWIN ELEMENT MODEL

This type of water heater has two heating units, each with its own thermostat. One heating unit is at the base of the water heater and the other near the top.

- **Bottom heating unit**
During normal operation this heating unit supplies all the hot water.
- **Top heating unit (Booster)**
This heating unit only operates during periods of high demand to provide an additional supply of heated water.
- **Electrical connection**
The two heating units are wired for non-simultaneous operation, so that only one heating unit can operate at a time. The bottom heating unit is usually connected to an Off-Peak (overnight) or time controlled supply and the top heating unit to a Continuous / Domestic supply. Some electricity suppliers allow both heating units to be metered at the Off-Peak or controlled tariff.



NOTE: Power must be available to the top heating unit circuit at all times for this water heater to operate as designed.

MAINS PRESSURE

The water heater is designed to operate at mains pressure by connecting directly to the mains water supply. If the mains supply pressure in your area exceeds that shown on page 23, a pressure limiting valve must be fitted. The supply pressure should be greater than 350 kPa for true mains pressure operation to be achieved.

PRECAUTIONS

Where damage to property can occur in the event of the water heater leaking, the water heater must be installed in a safe tray. Construction, installation and draining of a safe tray must comply with AS/NZS 3500.4 and all local codes and regulatory authority requirements.

The water heater must be maintained in accordance with the Owner's Guide and Installation Instructions. Refer to "[Maintenance Requirements](#)" on page 10 and to "[Anode Inspection and Replacement](#)" on page 15.

If this water heater is to be used where an uninterrupted hot water supply is necessary for your application or business you should ensure that you have back-up redundancy within the hot water system design. This should ensure the continuity of hot water supply in the event that this water heater were to become inoperable for any reason. We recommend you seek advice from your plumber or specifier about your needs and building back-up redundancy into your hot water supply system.

TO TURN OFF THE WATER HEATER

If you plan to be away from home for only a few nights, we suggest you leave the water heater switched on.

If it is necessary to turn off the water heater:

- Switch off the electrical supply at the isolating switch to the water heater.
- Unplug the power supply cord from the power outlet (power supply cord model only).
- Close the cold water isolation valve at the inlet to the water heater.

TO TURN ON THE WATER HEATER

- Open the cold water isolation valve fully on the cold water line to the water heater.
- Plug in the power supply cord at the power outlet (power supply cord model only).
- Switch on the electrical supply at the isolating switch to the water heater.

GOING ON HOLIDAY?

If you plan to be away from home for one or two nights, we suggest you leave the water heater switched on. However, if you plan to stay away more than a few nights, conserve energy by switching the water heater off at either the switchboard or isolating switch (if one is installed).

Note: When the electrical supply is switched back on, the water heater will take some time to reheat the water. Depending upon the power supply connection, hot water may not be available until the next day.

HOW DO I KNOW IF THE WATER HEATER IS INSTALLED CORRECTLY?

Installation requirements are shown on [pages 21 to 28](#). The water heater must be installed:

- by a qualified person, and
- in accordance with the installation instructions, and
- in compliance with Standards AS/NZS 3500.4, AS/NZS 3000 and all local codes and regulatory authority requirements.

VICTORIAN CUSTOMERS

Notice to Victorian Customers from the Victorian Plumbing Industry Commission. This water heater must be installed by a licensed person as required by the Victorian Building Act 1993. Only a licensed person will give you a Compliance Certificate, showing that the work complies with all the relevant Standards. Only a licensed person will have insurance protecting their workmanship for 6 years. Make sure you use a licensed person to install this water heater and ask for your Compliance Certificate.

DOES THE WATER CHEMISTRY AFFECT THE WATER HEATER?

The water heater is suitable for most public water supplies, however some water chemistries may have detrimental effects on the water heater, its components and fittings. Refer to [“Water Supplies”](#) on page 14.

If you are in a known harsh water area or you are not sure of your water chemistry, have your water checked against the conditions [described on pages 14 to 17](#).

HOW LONG WILL THE WATER HEATER LAST?

The water heater is supported by a manufacturer’s warranty ([refer to page 45](#)). There are a number of factors that will affect the length of service the water heater will provide. These include but are not limited to the water chemistry, the water pressure, the water temperature (inlet and outlet) and the water usage pattern. Refer to [“Precautions”](#) on page 8.

MAINTENANCE REQUIREMENTS

MAJOR SERVICE EVERY FIVE YEARS

It is recommended a major service be conducted on the water heater every five (5) years.

⚠ Warning: Servicing of a water heater must only be carried out by qualified personnel. Phone Rheem Service or their nearest Accredited Service Agent.

Note: The major service and routine replacement of any components, such as the anode and relief valve(s), are not included in the Rheem warranty. A charge will be made for this work. Only genuine replacement parts should be used on this water heater.

The major service includes the following actions:

- Replace the temperature limiting valve (RheemPlus model).
- Replace the temperature pressure relief valve.
- Inspect and flush the expansion control valve (if fitted). If required, replace the valve.
- Inspect and if required, replace the anode.

If the anode is not replaced, it should be replaced within three (3) years of this service (refer to **"Anode Inspection and Replacement"** on page 15).

- Check the electric heating unit for excessive calcium build-up or corrosion and replace if necessary.
- Visually check the unit for any potential problems.
- Inspect all connections.
- Check the drain line from the safe tray (if one is installed) is not blocked.

Note: The water heater may need to be drained during this service. After the completion of the service, the water heater will take some time to reheat the water. Depending upon the power supply connection, hot water may not be available until the next day.

MINOR MAINTENANCE EVERY SIX MONTHS

It is recommended minor maintenance be performed every six (6) months. Minor maintenance can be performed by the dwelling occupant.

The minor maintenance includes:

- Operate the easing lever on the temperature pressure relief valve. It is very important you raise and lower the lever gently. Refer to “**Temperature Pressure Relief Valve**” on page 12.

⚠ Warning: Exercise care to avoid any splashing of water, as water discharged from the drain line will be hot. Stand clear of the drain line’s point of discharge when operating the valve’s lever.

- Operate the easing lever on the expansion control valve (if fitted). It is very important you raise and lower the lever gently. Refer to “**Expansion Control Valve**” on page 11.
- Check the performance of the temperature limiting valve (RheemPlus model).

Measure the water temperature from the hot tap nearest to the water heater with a thermometer. If the water temperature exceeds 50°C, phone Rheem Service or their nearest Accredited Service Agent to arrange for an inspection. Refer to “**Temperature Limiting Valve**” on page 13.

- Check the drain line from the safe tray (if one is installed) is not blocked.

EXPANSION CONTROL VALVE

In many areas, including South Australia, Western Australia and scaling water areas, it is mandatory an expansion control valve is fitted to the cold water line to the water heater. The expansion control valve may discharge a small quantity of water from its drain line during the heating period instead of the temperature pressure relief valve on the water heater.

Operate the easing lever on the expansion control valve once every six months. Refer to “**Minor Maintenance Every Six Months**” on page 11. **It is very important the lever is raised and lowered gently.** If water does not flow freely from the drain line when the lever is lifted, then the water heater should be checked by Rheem Service or their nearest Accredited Service Agent. The expansion control valve should be checked for performance or replaced at intervals not exceeding five (5) years, or more frequently in areas where there is a high incidence of water deposits.

TEMPERATURE PRESSURE RELIEF VALVE

This valve is near the top of the water heater and is essential for its safe operation. It is possible for the valve to release a little water through the drain line during each heating period. This occurs as the water is heated and expands by approximately 1/50 of its volume.

Continuous leakage of water from the valve and its drain line may indicate a problem with the water heater (refer to “**Temperature Pressure Relief Valve Running**” on page 19).

⚠ Warning: Never block the outlet of this valve or its drain line for any reason.

Operate the easing lever on the temperature pressure relief valve once every six (6) months. Refer to “**Minor Maintenance Every Six Months**” on page 11. **It is very important the lever is raised and lowered gently.**

⚠ DANGER: Failure to do this may result in the water heater cylinder failing, or under certain circumstances, exploding.

⚠ Warning: Exercise care to avoid any splashing of water, as water discharged from the drain line will be hot. Stand clear of the drain line’s point of discharge when operating the valve’s lever.

If water does not flow freely from the drain line when the lever is lifted, then the water heater must be checked. Phone Rheem Service or their nearest Accredited Service Agent to arrange for an inspection.

The temperature pressure relief valve should be replaced at intervals not exceeding five (5) years, or more frequently in areas where there is a high incidence of water deposits (refer to “**Water Supplies**” on page 14).

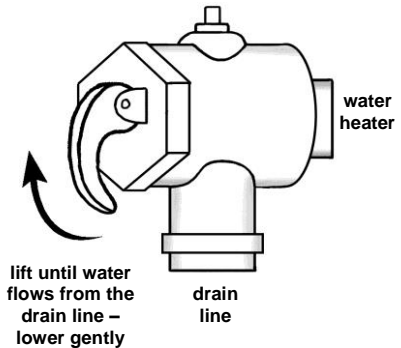
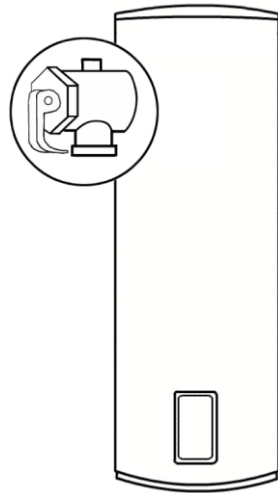

TEMPERATURE LIMITING VALVE

A RheemPlus water heater is fitted with a temperature limiting valve at the hot water outlet. The valve is set to deliver water not exceeding 50°C.

The valve should be checked for performance every twelve (12) months. This can be performed by measuring the water temperature from the hot tap nearest to the water heater with a thermometer. If the water being delivered is at a temperature exceeding 50°C, phone Rheem Service or their nearest Accredited Service Agent to arrange for an inspection.

The valve must be replaced at intervals not exceeding five (5) years, or more frequently in areas where there is a high incidence of water deposits (refer to **“Water Supplies”** on page 14). Failure to do this may result in water at a temperature up to 70°C being delivered at the hot tap, increasing the risk of scald injury.

WATER SUPPLIES

This water heater must be installed in accordance with this advice to be covered by the Rheem warranty.

This water heater is manufactured to suit the water conditions of most public reticulated water supplies. However, there are some known water chemistries which can have detrimental effects on the water heater and its operation and / or life expectancy. If you are unsure of your water chemistry, you may be able to obtain information from your local water supply authority. This water heater should only be connected to a water supply which complies with these guidelines for the Rheem warranty to apply.

ANODE

The vitreous enamel lined cylinder of the water heater is only covered by the Rheem warranty when the total dissolved solids (TDS) content in the water is less than 2500 mg/L and when the correct colour coded anode is used. If an incorrect colour coded anode is used in the water heater, any resultant faults will not be covered by the Rheem warranty. In addition, the use of an incorrect colour coded anode may shorten the life of the water heater cylinder.

The correct colour coded anode must be selected and fitted to the water heater in accordance with the following advice and the [Anode Selection chart](#) on page 15 for the Rheem warranty to apply to the water heater cylinder.

Total Dissolved Solids	Anode colour code
0 – 40 mg/L	Green
40 – 150 mg/L	Green or Black
150 – 400 mg/L	Black
400 – 600 mg/L	Black or Blue
600 – 2500 mg/L	Blue
2500 mg/L +	Blue (no cylinder warranty)

The changing of an anode must be carried out by a qualified person.

Note: Some water analysis reports may state the conductivity of the water rather than the level of total dissolved solids. Conductivity, measured in microsiemens per centimetre ($\mu\text{S} / \text{cm}$), is directly proportional to the TDS content of the water. TDS, in mg / L, is approximately 70% of the conductivity in $\mu\text{S} / \text{cm}$.

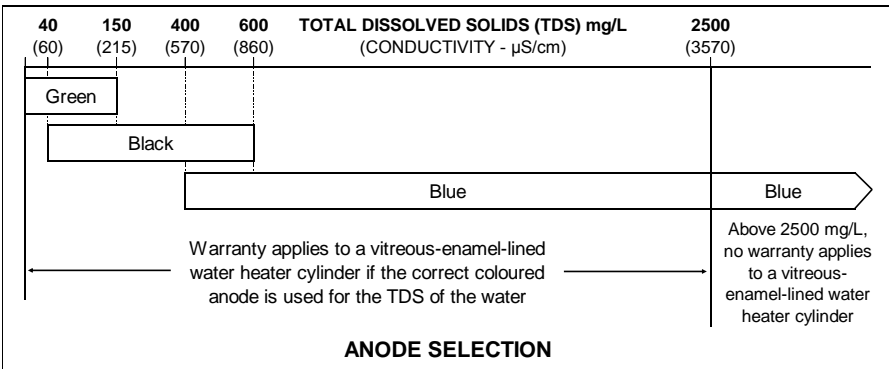

ANODE INSPECTION AND REPLACEMENT

The anode installed in your water heater will slowly dissipate whilst protecting the cylinder. The life of the cylinder may be extended by replacing the anode.

For water supplies which are either softened or desalinated, or where the water supply may alternate between a water tank and a reticulated public supply or another supply, or where there is a variable supply (e.g. from a bore or public reticulated supply from various water sources), the anode must be inspected (and replaced if there is any sign of depletion) within 5 years of its installation.

For all water supplies, if the anode is not replaced during a major service (refer to **“Major Service Every Five Years”** on page 10) then the maximum time after installation when the anode should be replaced for this water heater is 8 years.

CAUTION

If the water supply has a TDS greater than 150 mg/L and a green anode has not been changed to a black anode, or if the TDS is greater than 600 mg/L and the anode has not been changed to a blue anode, there is the possibility the anode may become overactive and hydrogen gas could accumulate in the top of the water heater during long periods of no use.

If, under these conditions, the water heater has not been used for two or more weeks the following procedure should be carried out before using any electrical appliances (automatic washing machines and dishwashers) which are connected to the hot water supply.

The hydrogen, which is highly flammable, should be vented safely by opening a hot tap and allowing the water to flow. There should be no smoking or naked flame near the tap whilst it is turned on. Any hydrogen gas will be dissipated. This is indicated by an unusual spurting of the water from the tap. Once the water runs freely, any hydrogen in the system will have been released.

SATURATION INDEX

The saturation index is used as a measure of the water’s corrosive or scaling properties. The saturation index figures stated are calculated using a water temperature of 80°C.

In a corrosive water supply, the water can attack copper parts and cause them to fail. Where the saturation index is less than -1.0, the water is very corrosive and the Rheem warranty does not apply to a copper sheathed heating unit. A corrosion resistant heating unit must be used for the Rheem warranty to apply to the heating unit.

In a scaling water supply calcium carbonate is deposited out of the water onto any hot metallic surface. Where the saturation index exceeds +0.40, the water is very scaling. An expansion control valve must be fitted on the cold water line after the non-return valve to protect and for the Rheem warranty to apply to the temperature pressure relief valve and water heater cylinder.

Where the saturation index exceeds +0.80, the Rheem warranty does not apply to a standard watts density heating unit. A low watts density heating unit must be used for the Rheem warranty to apply to the heating unit.

Water which is scaling may be treated with a water softening device to reduce the saturation index of the water.

Refer to the **Saturation Index chart** on page 16. Refer to the **cold water connection detail on page 32** for the position of the expansion control valve.

Contact Rheem Service or their nearest Accredited Service Agent if a replacement heating unit is required.

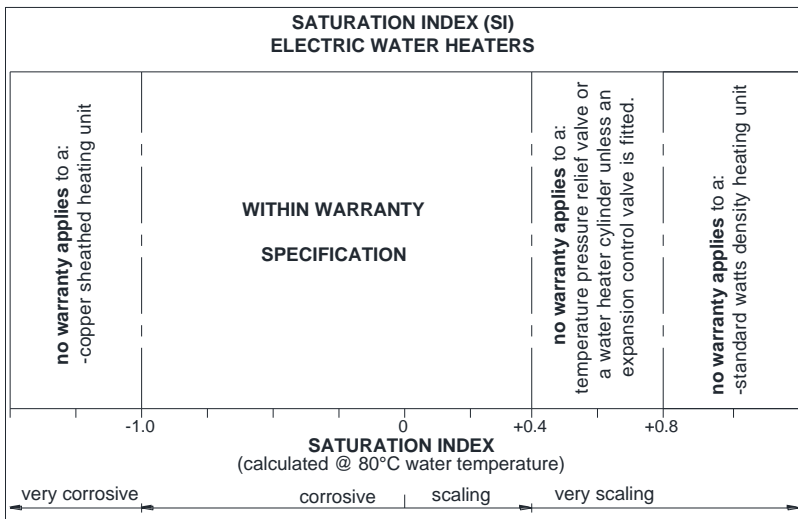

CHANGE OF WATER SUPPLY

The changing or alternating from one water supply to another can have a detrimental effect on the operation and / or life expectation of a water heater cylinder, a temperature pressure relief valve and a heating unit.

Where there is a changeover from one water supply to another, e.g. a rainwater tank supply, bore water supply, desalinated water supply, public reticulated water supply or water brought in from another supply, then water chemistry information should be sought from the supplier or it should be tested to ensure the water supply meets the requirements given in these guidelines for the Rheem warranty to apply.

SUMMARY OF WATER CHEMISTRY ADVICE AFFECTING WARRANTY

The water heater and its components are not suitable for certain water chemistries. Those chemistries are listed below. If the water heater is connected at any time to a water supply with the following water chemistry, the Rheem warranty will not cover any resultant faults on the components listed below:

Water Chemistry	Component
Total Dissolved Solids (TDS) > 2500 mg/L	water heater cylinder
Total Dissolved Solids (TDS) not suitable for anode type	water heater cylinder
Saturation Index (SI) < -1.0	copper sheathed heating unit
Saturation Index (SI) > +0.4 (if expansion control valve is not fitted)	water heater cylinder temperature pressure relief valve
Saturation Index (SI) > +0.8	standard watts density heating unit

SAVE A SERVICE CALL

Check the items below before making a service call. You will be charged for attending to any condition or fault that is not related to the manufacture or failure of a part.

NOT ENOUGH HOT WATER (OR NO HOT WATER)

- **Is the electricity switched on?**

Inspect the isolating switch marked “HOT WATER” or “WATER HEATER” at the switchboard and the isolating switch (if one is installed) near the water heater and ensure they are turned on.

Note: Check the electricity supply to which the water heater is connected. If on an Off-Peak or time controlled electricity supply, remember heating hours are restricted. Refer to [“Off-Peak Electricity Supply”](#) on page 7.



Check the fuse marked “HOT WATER” or “WATER HEATER” at the switchboard.

- **Twin element water heaters**

A twin element non-simultaneous model must have power available to the top heating unit circuit at all times for the water heater to operate as designed.

- **Are you using more hot water than you think?**

Is one outlet (especially the shower) using more hot water than you think? Very often it is not realised the amount of hot water used, particularly when showering. Carefully review the family’s hot water usage. Have your plumber fit a flow control valve to each shower outlet to reduce water usage.

- **Temperature pressure relief valve running**

Is the relief valve discharging too much water? Refer to [“Temperature Pressure Relief Valve Running”](#) on page 19.

- **Thermostat setting**

Ensure the thermostat setting is appropriate. You may choose to have your electrician check and adjust the thermostat upwards to gain additional hot water capacity. Refer to [“Temperature Adjustment”](#) on page 5.

⚠ Warning: Hotter water increases the risk of scald injury.

A RheemPlus water heater is temperature limited to 50°C at the hot water outlet. Increasing the thermostat setting will not increase the outlet temperature but will provide more hot water capacity.

- **Water heater size**

Do you have the correct size water heater for your requirements? The sizing guide in the Rheem sales literature and on the Rheem website (www.rheem.com.au) suggests average sizes that may be needed.

WATER TEMPERATURE TOO HIGH

A RheemPlus water heater is fitted with a temperature limiting valve set to deliver water not exceeding 50°C. If the water is being delivered at a temperature exceeding 50°C, phone Rheem Service or their nearest Accredited Service Agent to arrange for an inspection. Care must be taken by all householders when using hot water until the valve is serviced or replaced.

TEMPERATURE PRESSURE RELIEF VALVE RUNNING

- **Normal Operation**

It is normal and desirable that this valve allows a small quantity of water to escape during the heating cycle. However, if it discharges more than a bucket full of water in 24 hours, there may be another problem.

- **Continuous dribble**

Try gently raising the easing lever on the relief valve for a few seconds (refer to “**Temperature Pressure Relief Valve**” on page 12). This may dislodge a small particle of foreign matter and clear the fault. Release the lever gently.

- **Steady flows for long period (often at night)**

This may indicate the mains water pressure sometimes rises above the designed pressure of the water heater. Ask your installing plumber to fit a pressure limiting valve.

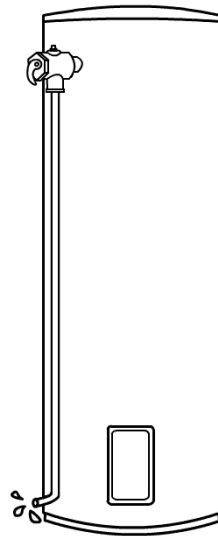

⚠ Warning: Never replace the relief valve with one of a higher pressure rating.

- **Heavy flows of hot water until water heater is cold - then stops until water reheats**

The water heater **must** be switched off at the switchboard. Phone Rheem Service or their nearest Accredited Service Agent to arrange for an inspection.

EXPANSION CONTROL VALVE RUNNING

If an expansion control valve is fitted in the cold water line to the water heater (refer to the **cold water connection diagram** on page 32) it may discharge a small quantity of water instead of the temperature pressure relief valve on the water heater. The benefit is that energy is conserved as the discharged water is cooler.

HIGHER THAN EXPECTED ELECTRICITY BILLS

Should you at any time, feel your electricity bill is higher than expected, we suggest you check the following points:

- Is the relief valve running excessively?

Refer to **“Temperature Pressure Relief Valve Running”** on page 19.

- Is one outlet (especially the shower) using more hot water than you think?

Refer to **“Not Enough Hot Water”** on page 18.

- Is there a leaking hot water pipe, dripping hot water tap, etc?

Even a small leak will waste a surprising quantity of hot water and electricity. Replace faulty tap washers, and have your plumber rectify any leaking pipe work.

- Has there been an increase in hot water usage?

An increase in hot water usage will result in an increase in water heater operation.

- Has your water heating tariff rate been increased by your electricity retailer since your previous bill?

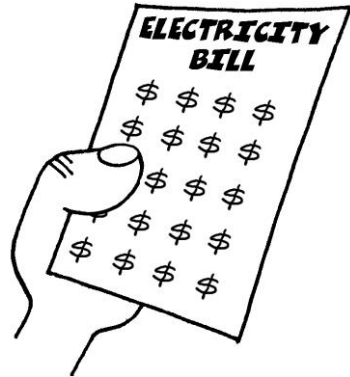

ELECTRICITY TARIFFS

The electricity tariff to which your water heater is connected will determine the overall operating cost of the system. It is important you are aware of this tariff, i.e. Off-Peak (overnight) or time controlled supply, Extended Off-Peak (overnight and day) or Extended time controlled supply, Domestic / Continuous. For types of tariffs, refer to **“Single Element Model”** on page 7 and **“Twin Element Model”** on page 7.

IF YOU HAVE CHECKED ALL THE FOREGOING AND STILL BELIEVE YOU NEED ASSISTANCE, PHONE RHEEM SERVICE OR THEIR NEAREST ACCREDITED SERVICE AGENT.

INSTALLATION

THIS WATER HEATER IS NOT SUITABLE FOR POOL HEATING

INSTALLATION STANDARDS

The water heater must be installed:

- by a qualified person, and
- in accordance with the installation instructions, and
- in compliance with Standards AS/NZS 3500.4, AS/NZS 3000 and all local codes and regulatory authority requirements.

All packaging materials must be removed from the water heater prior to its installation. This includes the removal of the cardboard base of the carton from the underside of the water heater.

WATER HEATER APPLICATION

This water heater is designed for use in a single family domestic dwelling for the purpose of heating potable water. Its use in an application other than this may shorten its life.

If this water heater is to be used where an uninterrupted hot water supply is necessary for the application or business, then there should be back-up redundancy within the hot water system design. This should ensure the continuity of hot water supply in the event that this water heater was to become inoperable for any reason. We recommend you provide advice to the system owner about their needs and building back-up redundancy into the hot water supply system.

WATER HEATER LOCATION

The water heater is suitable for either indoor or outdoor installation, except a water heater supplied with a power supply cord and plug is suitable for indoor installation only. Whether located outdoor or indoor, the water heater should be installed close to the most frequently used outlet and its position chosen with safety and service in mind.

Clearance must be allowed for servicing of the water heater. The water heater must be accessible without the use of a ladder or scaffold.

Make sure the temperature pressure relief valve lever is accessible and the front cover, thermostat, heating unit and if fitted, the side cover and temperature limiting valve can be removed for service.

You must be able to read the information on the rating plate. If possible leave headroom of one water heater height so the anode can be inspected or replaced. Remember you may have to take the entire water heater out later for servicing.

The water heater is to be installed at ground or floor level and must stand vertically upright on a stable base as acceptable to local authorities. The base of the water heater is made of corrosion resistant material, and it may be placed directly in contact with the supporting surface. It is not necessary to allow for free air circulation under the base of the water heater.

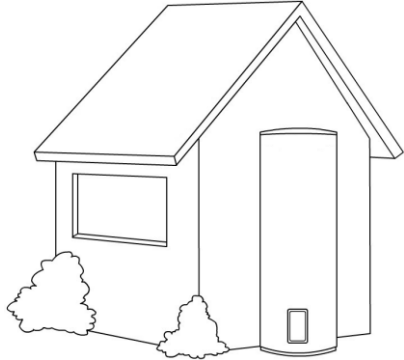

Note: The water heater should not be placed in direct contact with a concrete surface that is less than two months old and not fully cured as this may attack the metal coating of the water heater base. A moisture barrier should be used between the two surfaces in this instance.

Alternatively, a 025 to 080 model may be hung on a wall capable of taking the weight of the filled water heater. A wall bracket kit (PN 299120) is available from Rheem. Refer to the instructions supplied with the kit.

Remember all local authorities have regulations about putting water heaters into roof spaces.

SAFE TRAY

Where damage to property can occur in the event of the water heater leaking, the water heater must be installed in a safe tray. Construction, installation and draining of a safe tray must comply with AS/NZS 3500.4 and all local codes and regulatory authority requirements. AS/NZS 3500.4 also has particular requirements when a safe tray must be installed.

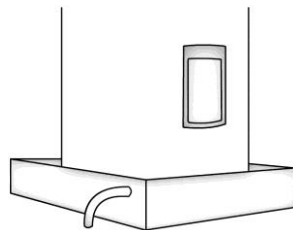

MAINS WATER SUPPLY

Where the mains water supply pressure exceeds that shown in the table below, an approved pressure limiting valve is required and should be fitted as shown in the **cold water connection diagram** on page 32.

Model	025 to 160	250 to 315
Temp press relief valve setting	1400 kPa	1000 kPa
Expansion control valve setting*	1200 kPa	850 kPa
Max. mains supply pressure		
With expansion control valve	960 kPa	680 kPa
Without expansion control valve	1120 kPa	800 kPa

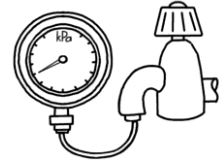

* Expansion control valve not supplied with water heater

TANK WATER SUPPLY

If the water heater is supplied with water from a tank supply and a pressure pump system is not installed, then the bottom of the supply tank must be at least 1 m above the highest point of the hot water plumbing system, including the water heater. Care must be taken to avoid air locks. The cold water line to the water heater should be adequately sized and fitted with a full flow gate valve or ball valve.

PUSH THROUGH (FREE OUTLET) INSTALLATION

It can be advantageous to plumb a 025 or 050 model water heater as a Push Through water heater in some cases.

These installations can supply a single point non-tempered non-ablution outlet only. The temperature pressure relief valve supplied with this model **must** be fitted to the water heater.

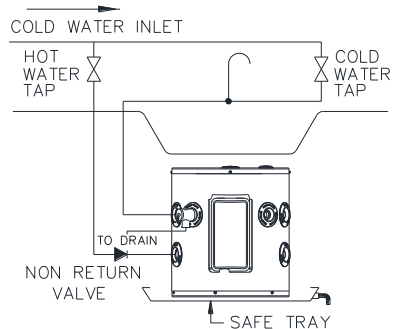

HOT WATER DELIVERY

This water heater can deliver water at temperatures which can cause scalding.

It is necessary and we recommend that a temperature limiting device be fitted between a Rheemglas water heater and the hot water outlets in any ablution area such as a bathroom or ensuite, to reduce the risk of scalding. The installing plumber may have a legal obligation to ensure the installation of this water heater meets the delivery water temperature requirements of AS/NZS 3500.4 so that scalding water temperatures are not delivered to a bathroom, ensuite or other ablution area.

Where a temperature limiting device is installed adjacent to the water heater, the cold water line to the temperature limiting device can be branched off the cold water line either before or after the isolation valve, pressure limiting valve and non-return valve to the water heater. If an expansion valve is required, it must always be installed after the non-return valve and be the last valve prior to the water heater.

If a pressure limiting valve is installed on the cold water line to the water heater and the cold water line to a temperature limiting device branches off before this valve or from another cold water line in the premises, then a pressure limiting valve of an equal pressure setting may be required prior to the temperature limiting device.

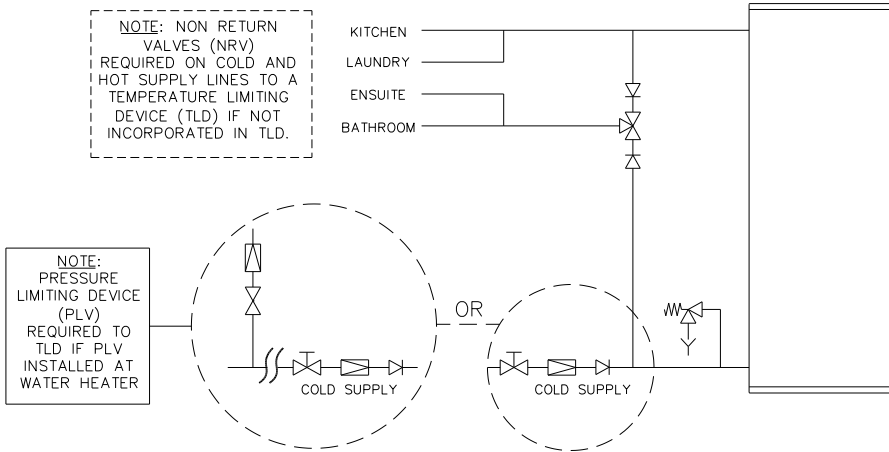

Two Temperature Zones Using a Temperature Limiting Device

A RheemPlus water heater will not deliver temperatures exceeding 50°C, in accordance with AS 3498. There is no need to fit a temperature limiting device to satisfy the requirements of AS/NZS 3500.4, if a RheemPlus water heater is installed in an application where 50°C is the maximum permissible hot water temperature at the outlet of a sanitary fixture used primarily for personal hygiene purposes.

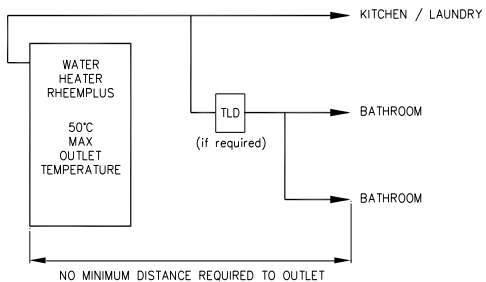

CIRCULATED HOT WATER FLOW AND RETURN SYSTEM

A RheemPlus water heater cannot be installed as part of a circulated hot water flow and return system in a building.

If a Rheem water heater is to be installed as part of a circulated hot water flow and return system, it must be able to provide a hot water outlet temperature of at least 60°C. **Note:** The thermostat must always be set to at least 60°C.

Refer to the **Circulated Hot Water Flow and Return – Continuous Electric Water Heater** diagram on page 25.

Temperature Limiting Device

A temperature limiting device cannot be installed in circulated hot water flow and return pipe work. The tempered water from a temperature limiting device cannot be circulated. Where a circulated hot water flow and return system is required in a building, a temperature limiting device can only be installed on a dead leg, branching off the circulated hot water flow and return pipe.

If circulated tempered water were to be returned back to the water heater, depending on the location of the return line connection on the water supply line to the water heater, then either:

- water will be supplied to the cold water inlet of the temperature limiting device at a temperature exceeding the maximum recommended water supply temperature, or
- when the hot taps are closed no water will be supplied to the cold water inlet of the temperature limiting device whilst hot water will continue to be supplied to the hot water inlet of the temperature limiting device.

These conditions may result in either water at a temperature exceeding the requirements of AS/NZS 3500.4 being delivered to the hot water outlets in the ablution areas, or the device closing completely and not delivering water at all, or the device failing. Under either condition, the operation and performance of the device cannot be guaranteed.

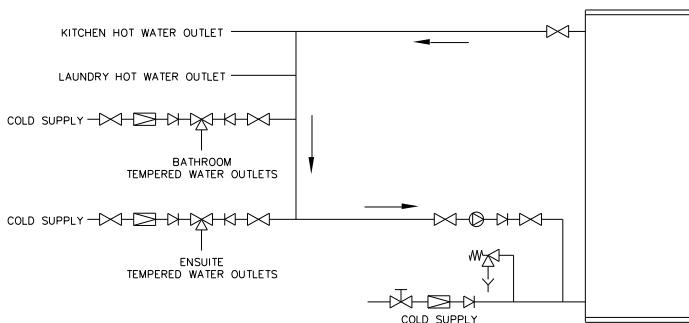

Circulated Hot Water Flow and Return – Continuous Electric Water Heater

Off-Peak or Time Controlled Electricity Supply

A single or twin element electric water heater connected to an Off-Peak electricity supply should not be installed as part of a circulated hot water flow and return system in a building. The benefits of the Off-Peak electricity supply will be significantly reduced.

If a circulated flow and return system is required, it is necessary to install a secondary water heater supplied from the Off-Peak electric water heater. The flow and return lines connect to the secondary water heater, not the Off-Peak electric water heater. The secondary water heater makes up for the pipe heat loss in the flow and return system and must be able to provide a hot water outlet temperature of at least 60°C.

Note: The thermostat or preset outlet temperature of the secondary water heater must always be set to maintain a temperature of at least 60°C in the hot water flow and return line, including making up pipe heat losses in the system.

Refer to the **Circulated Hot Water Flow and Return – Off-Peak Electric Water Heater** diagram on page 26.

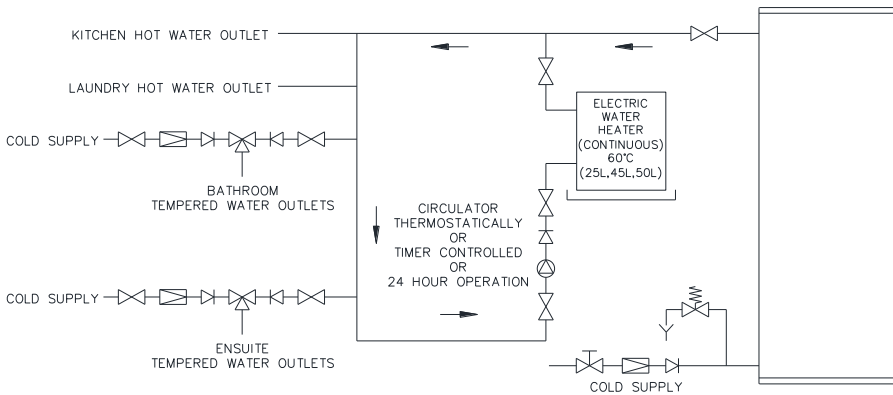

NOTE: A PLV IS REQUIRED TO BE INSTALLED ON THE COLD SUPPLY LINE TO THE TEMPERING VALVE IF A PLV IS INSTALLED ON THE COLD SUPPLY LINE TO THE WATER HEATER.

Circulated Hot Water Flow and Return System Off-Peak Electric Water Heater

REDUCING HEAT LOSSES

The cold water line to and the hot water line from the water heater must be insulated in accordance with the requirements of AS/NZS 3500.4. The insulation must be weatherproof and UV resistant if exposed.

ANODE

The vitreous enamel lined cylinder of the water heater is only covered by the Rheem warranty when the total dissolved solids (TDS) content in the water is less than 2500 mg/L and when the correct colour coded anode is used. If an incorrect colour coded anode is used in the water heater, any resultant faults will not be covered by the Rheem warranty. In addition, the use of an incorrect colour coded anode may shorten the life of the water heater cylinder.

The correct colour coded anode for the water supply being used must be selected and fitted to the water heater for the Rheem warranty to apply to the water heater cylinder (refer to “**Water Supplies**” on page 14 and the **Anode Selection chart** on page 15). The black anode is typically fitted as standard.

Total Dissolved Solids	Anode colour code
0 – 40 mg/L	Green
40 – 150 mg/L	Green or Black
150 – 400 mg/L	Black
400 – 600 mg/L	Black or Blue
600 – 2500 mg/L	Blue
2500 mg/L +	Blue (no cylinder warranty)

If the water supply has a TDS greater than 150 mg/L and a green anode has not been changed to a black anode, or if the TDS is greater than 600 mg/L and the anode has not been changed to a blue anode, there is the possibility the anode may become overactive and hydrogen gas could accumulate in the top of the water heater during long periods of no use. In areas where this is likely to occur, the installer should instruct the householder on how to dissipate the gas safely (refer to “**Caution**” on page 15).

SADDLING PIPE WORK

To prevent damage to the cylinder when attaching pipe clips or saddles to the water heater jacket, we recommend the use of self-drilling screws with a maximum length of 13 mm. Should pre-drilling be required, extreme caution must be observed when penetrating the jacket of the water heater.

Note: If the cylinder is damaged as a result of attaching pipe clips or saddles to the jacket, any resultant faults will not be covered by the Rheem warranty.

TYPICAL INSTALLATION – OUTDOOR LOCATION

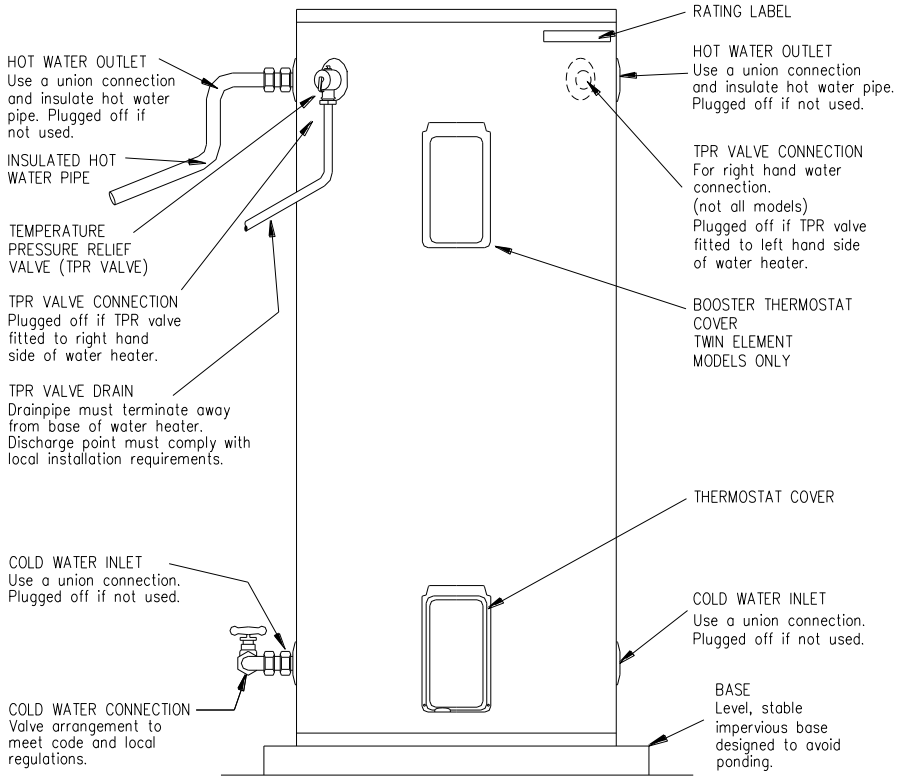

TYPICAL INSTALLATION – INDOOR LOCATION

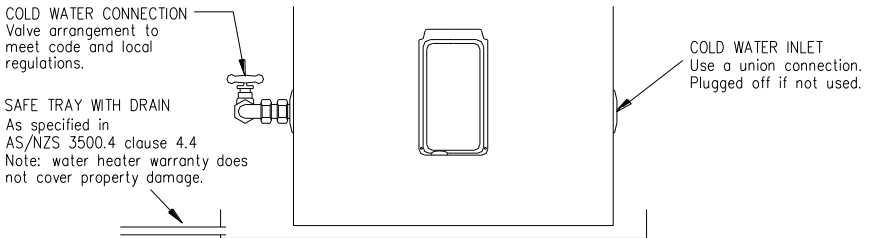

DIMENSIONS AND TECHNICAL DATA – RHEEMGLAS 025 TO 050 MODELS

Note: 111025 models have the water and TPR valve fittings on the left hand side only.

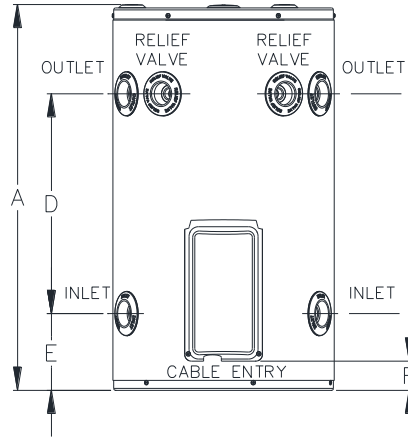
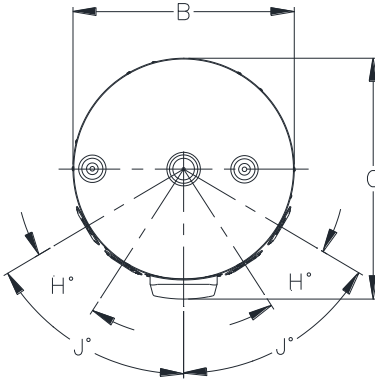

Rheemglas Single Element	LH	111025	-
Rheemglas Single Element	DH	-	191050
Hot Water Delivery	Litres	18	50
Dimensions	A	mm	390
	B	mm	385
	C	mm	420
	D	mm	130
	E	mm	116
	F	mm	60
	H	deg	26
	J	deg	65
TPR Valve Setting	kPa	1400	1400
Approx. Weight empty	kg	18	26

All models are suitable for either indoor or outdoor installation, except a water heater supplied with a power supply cord and plug ('/P' suffix) is suitable for indoor installation only.

111025 models have left hand (LH) water and TPR valve connections only.

191050 models have left and right hand (dual handed - DH) water and TPR valve connections.

Technical data is subject to change.

DIMENSIONS AND TECHNICAL DATA – RHEEMGLAS 080 TO 160 MODELS

Note: 191, 192160 models have the TPR valve fitting on the left hand side only.

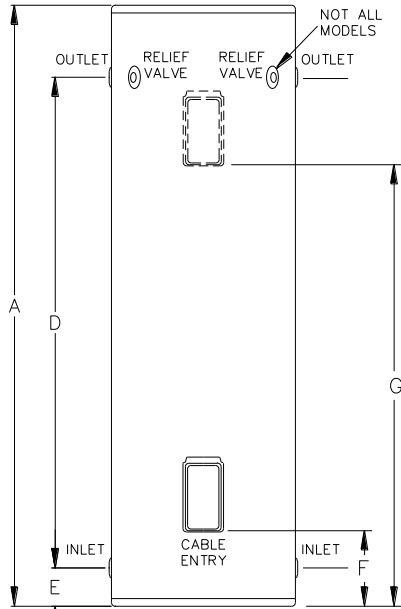
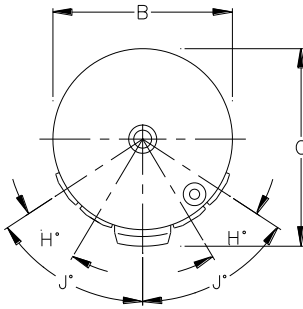

Rheemglas Single Element	DH		191080	191125	191160
Rheemglas Twin Element	DH		-	-	192160
Hot Water Delivery	Litres		80	125	160
Boost Capacity	Litres		-	-	45
Dimensions	A	mm	945	1340	1610
	B	mm	480	480	480
	C	mm	515	515	515
	D	mm	702	1102	1332
	E	mm	64	64	104
	F	mm	66	66	66
	G	mm	-	-	1081
	H	deg	24	24	23
	J	deg	60	60	58
TPR Valve Setting	kPa		1400	1400	1400
Approx. Weight empty	kg		36	49	55

All models are suitable for either indoor or outdoor installation.

191 series 080 to 125 models have left and right hand (dual handed - DH) water and TPR valve connections.

191, 192 series 160 models have left and right hand (dual handed - DH) water connections and a TPR valve fitting on the left hand side only.

Technical data is subject to change.

DIMENSIONS AND TECHNICAL DATA – RHEEMPLUS 125 TO 315 MODELS

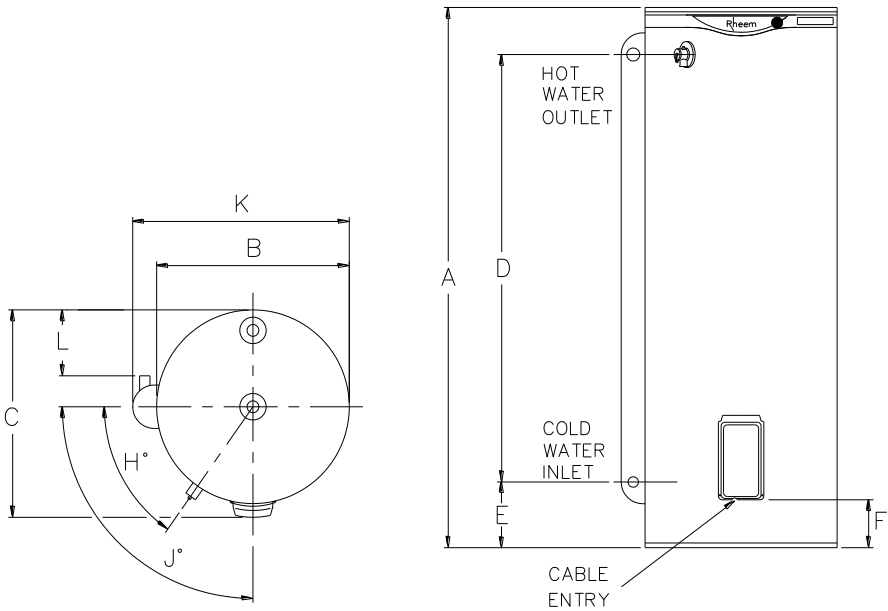

RheemPlus Single Element		LH	121125	121160	121250	121315
Hot Water Delivery		Litres	125	160	250	315
Dimensions	A	mm	1340	1610	1395	1640
	B	mm	480	480	640	640
	C	mm	515	515	680	680
	D	mm	1102	1332	1117	1317
	E	mm	64	104	73	113
	F	mm	66	66	103	103
	H	deg	23	23	32	32
	J	deg	58	58	88	88
	K	mm	545	545	705	705
L	mm	183	183	262	262	
TPR Valve Setting		kPa	1400	1400	1000	1000
Approx. Weight empty		kg	49	57	74	99

All models are suitable for either indoor or outdoor installation.
 121 series models have left hand (LH) water and TPR valve connections only.
 Technical data is subject to change.

CONNECTIONS – PLUMBING

All plumbing work must be carried out by a qualified person and in accordance with the Standard AS/NZS 3500.4 and all local codes and regulatory authority requirements.

CONNECTION SIZES

	Rheemglas	RheemPlus
• Hot water connection:	Rp 3/4	G 3/4 B
• Cold water connection:	Rp 3/4	G 3/4 B
• Relief valve connection:	Rp 1/2	Rp 1/2

WATER INLET AND OUTLET

Rheemglas 050 to 160 models have dual handed cold and hot water connections. The water connections can be made to either side. Rheemglas 025 and RheemPlus 160 to 315 models have cold and hot water connections on the left hand side only.

All pipe work must be cleared of foreign matter before connection and purged before attempting to operate the water heater. All olive compression fittings must use brass or copper olives. Use an approved thread sealant such as Teflon tape on all threaded joints.

An isolation valve and non-return valve must be installed on the cold water line to the water heater. An acceptable arrangement is shown in the diagram. Refer also to “**Hot Water Delivery**” on page 23 and to “**Mains Water Supply**” on page 23.

A disconnection union must always be provided at the cold water inlet and hot water outlet on the water heater to allow for disconnection of the water heater.

This water heater has either a plastic dip tube or fitting liner in the inlet and outlet fittings (see diagram). These must be in place for the water heater to function properly. Do not remove or damage them by using heat nearby. They will be pushed into the correct position as the fitting is screwed in.

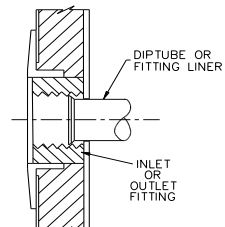
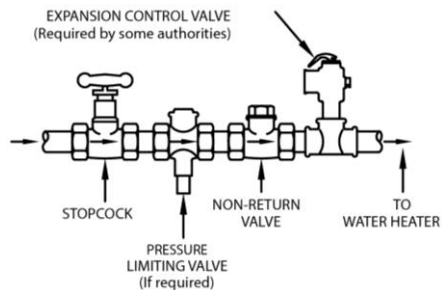

LEFT AND RIGHT HAND SIDE WATER CONNECTIONS

The cold and hot water supplies (050 to 160 Rheemglas models) and temperature pressure relief valve (050 to 125 Rheemglas models) can be connected to either side of a water heater. A kit is supplied with the water heater to plug off the unused cold water and hot water fittings, and where applicable the unused temperature pressure relief valve fitting.

The kit contains:

Models 050 to 125

- 2 x 3/4" brass plugs
- 1 x 1/2" brass plug
- 3 x plastic caps
- 3 x insulation rubber discs, pre-fitted into plastic caps

Models 160

- 2 x 3/4" brass plugs
- 2 x plastic caps
- 2 x insulation rubber discs, pre-fitted into plastic caps

Plugging Off Unused Connections

- Apply approved sealing tape or compound to the thread of each plug.
- Fit the 3/4" plugs to the unused cold water fitting and unused hot water fitting. Tighten the plugs using either a 12 mm A/F hex driver or a 3/8" square driver, as appropriate.
- Fit the 1/2" plug to the unused TPR valve fitting (050 to 125 models). Tighten the plug using either a 12 mm A/F hex driver or a 3/8" square driver, as appropriate.
- Fit a plastic cap with its insulation rubber disc over each plug.

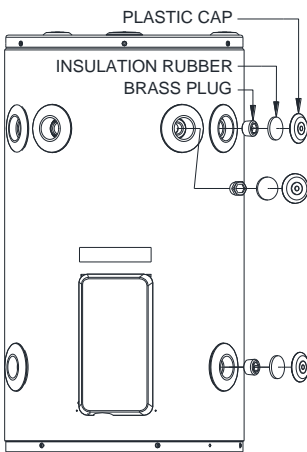

050 models

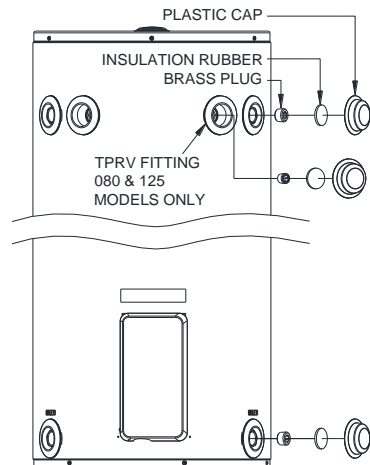

080 to 160 models

PIPE SIZES

To achieve true mains pressure operation, the cold water line to the water heater should be the same size or bigger than the hot water line from the water heater.

The pipe sizing for hot water supply systems should be carried out by persons competent to do so, choosing the most suitable pipe size for each individual application. Reference to the technical specifications of the water heater and local regulatory authority requirements must be made.

TEMPERATURE PRESSURE RELIEF VALVE

The temperature pressure relief valve is shipped either under the top flap of the water heater carton or behind the front cover or in a plastic bag attached to the water heater. The temperature pressure relief valve must be fitted before the water heater is operated. Before fitting the relief valve, make sure the probe has not been bent. Seal the thread with an approved thread sealant such as Teflon tape - never hemp. Make sure the tape does not hang over the end of the thread.

The water heater has a temperature pressure relief valve connection on its left hand side. Rheemglas 050 to 125 models have a second temperature pressure relief valve connection on the right hand side.

Screw the valve into the selected opening labelled “Relief Valve” (refer to the [installation diagram](#) on page 28) leaving the valve outlet pointing downwards. Do not use a wrench on the valve body - use the spanner flats provided. A copper drain line must be fitted to the temperature pressure relief valve (refer to ["Relief Valve Drain"](#) on page 36). If the water heater has a second relief valve fitting, refer to ["Left and Right Hand Side Water Connections"](#) on page 33.

The valve must be insulated with closed cell polymer insulation or similar (minimum thickness 9 mm) and the insulation installed so as not to impede the operation of the valve. The insulation must be weatherproof and UV resistant if exposed.

Where a flexible insulation collar is supplied with the temperature pressure relief valve, this must be placed over the body of the valve. If the insulation collar is of a firmer preformed type, it must be secured in position with the cable tie provided after the valve has been fitted to the water heater (refer to the [diagrams](#) on page 35).

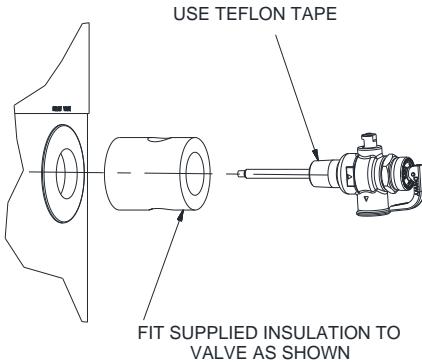

flexible insulation collar

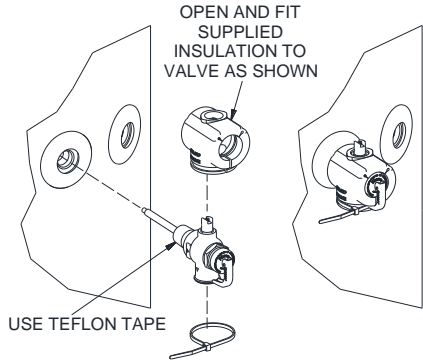

preformed insulation collar

EXPANSION CONTROL VALVE

Local regulations may make it mandatory to install an expansion control valve (ECV) in the cold water line to the water heater. In other areas, an ECV is required if the saturation index is greater than +0.4 (refer to **"Water Supplies"** on page 14).

The expansion control valve must always be installed after the non-return valve and be the last valve installed prior to the water heater (refer to the **cold water connection diagram** on page 32). A copper drain line must be fitted to the expansion control valve (refer to **"Relief Valve Drain"** on page 36).

The valve, if installed within 500 mm of the water heater, must be insulated with closed cell polymer insulation or similar (minimum thickness 9 mm) and the insulation installed so as not to impede the operation of the valve. The insulation must be weatherproof and UV resistant if exposed.

RELIEF VALVE DRAIN

DN15 copper drain lines must be fitted to the temperature pressure relief valve and expansion control valve (if one is installed) to carry the discharge clear of the water heater. Connect the drain lines to the valves using disconnection unions. The drain line from the valve to the point of discharge should be as short as possible, have a continuous fall all the way from the water heater to the discharge outlet and have no tap, valves or other restrictions in the pipe work. A drain line from a relief valve must comply with the requirements of AS/NZS 3500.4.

A drain line must be no longer than nine (9) metres with no more than three bends greater than 45° before discharging at an outlet or air break. The maximum length of nine (9) metres for a drain line is reduced by one (1) metre for each additional bend required of greater than 45°, up to a maximum of three additional bends. Where the distance to the point of final discharge exceeds this length, the drain line can discharge into a tundish.

Subject to local regulatory authority approval, the drain lines from the temperature pressure relief valve and expansion control valve from an individual water heater may be interconnected.

The outlet of a drain line must be in such a position that flow out of the pipe can be easily seen, but arranged so discharge will not cause injury, damage or nuisance. The termination point of a drain line must comply with the requirements of AS/NZS 3500.4. Drain lines must not discharge into a safe tray.

In locations where water pipes are prone to freezing, drain lines must be insulated, must not exceed 300 mm in length and are to discharge into a tundish through an air gap of between 75 mm and 150 mm.

If a drain line discharges into a tundish, the drain line from the tundish must be not less than DN20. The drain line from a tundish must meet the same requirements as for a drain line from a relief valve.

Warning: As the function of the temperature pressure relief valve on this water heater is to discharge high temperature water under certain conditions, it is strongly recommended the pipe work downstream of the relief valve be capable of carrying water exceeding 93°C. Failure to observe this precaution may result in damage to pipe work and property.

CONNECTIONS – ELECTRICAL

The power supply to the water heater must not be switched on until the water heater is filled with water and a satisfactory megger reading is obtained.

All electrical work and permanent wiring must be carried out by a qualified person and in accordance with the Wiring Rules AS/NZS 3000 and all local codes and regulatory authority requirements.

WATER HEATER

A water heater not fitted with a supply cord and plug must be directly connected to a 240 V AC, 50 Hz mains power supply with an isolating switch installed at the switchboard.

The power supply to a **twin element model** should be Off-Peak (overnight) to the **bottom heating unit** and continuous to the **top heating unit**. The power supply to a **single element model** can be either an **Off-Peak (overnight)**, **Extended Off-Peak (overnight and day)** or **continuous** electricity supply, depending upon the size of the water heater. Check with the local electricity supply authority as to their requirements. An Off-Peak (overnight) power supply will provide the maximum financial savings. Discuss the power supply requirements with the householder.

A flexible 20 mm conduit is required for the electrical cable to the water heater. The conduit is to be connected to the unit with a 20 mm terminator. Connect the power supply wires directly to the terminal block and earth tab connection, ensuring there are no excess wire loops inside the front cover. The temperature rating of the power supply wires insulation must suit this application.

A water heater fitted with a supply cord and plug must be plugged into a switched 240 V AC, 50 Hz mains power outlet rated at 10 A.

THERMOSTAT SETTING

The thermostat on a Rheemglas (bottom thermostat on a twin element model) and RheemPlus model is tradesperson adjustable from 60°C to 70°C (60°C to 75°C on a 050 model). The factory setting of the thermostat is 70°C for 025, 080 to 315 models and 75°C for 050 models.

The thermostat is adjusted by turning the adjuster anticlockwise to decrease the temperature setting and clockwise to increase the temperature setting. Only adjust the thermostat setting when the isolating switch is switched off at the switchboard. The top thermostat on a twin element model is fixed at 60°C and cannot be adjusted.

The thermostat of a RheemPlus model should not be set to less than 65°C. This is to assist in the specified operation of the temperature limiting valve.

For reasons of safety and economy, we advise the thermostat be set at the lowest temperature that will provide sufficient hot water. Dishwasher running costs can be adversely affected if the thermostat is set below 65°C. Discuss the thermostat setting requirements with the householder.

**WIRING DIAGRAM TWIN ELEMENT ELECTRIC WATER HEATERS
NON-SIMULTANEOUS OPERATION OFF-PEAK CONNECTION**

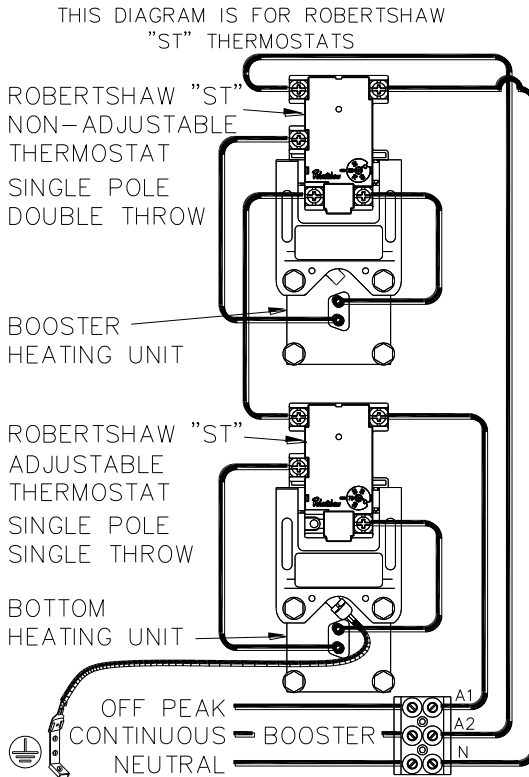

Top thermostat – fixed setting

60°C.

Bottom thermostat – tradesperson adjustable

min 60°C, max 70°C.

Electrical Circuit for Twin Element Models – Robertshaw "ST" Thermostats

The active from the continuous supply must be connected to the top heating unit circuit and the active from the Off-Peak or time controlled supply must be connected to the bottom heating unit circuit.

COMMISSIONING

TO FILL AND TURN ON THE WATER HEATER

The power supply to the water heater must not be switched on until the water heater is filled with water and a satisfactory megger reading is obtained.

- Open all of the hot water taps in the house (don't forget the shower).
- Open the cold water isolation valve fully on the cold water line to the water heater.

Air will be forced out of the taps.

- Close each tap as water flows freely from it.
- Check the pipe work for leaks.
- Plug in the power supply cord at the power outlet (power supply cord model only).
- Switch on the electrical supply at the isolating switch to the water heater.

If it is necessary to adjust the outlet temperature of a RheemPlus model, refer to **“Outlet Temperature Compensation Adjustment – RheemPlus”** on page 40.

Explain to the householder or a responsible officer the functions and operation of the water heater. Upon completion of the installation and commissioning of the water heater, leave this guide with the householder or a responsible officer.

TO TURN OFF THE WATER HEATER

If it is necessary to turn off the water heater on completion of the installation, such as on a building site or where the premises is vacant, then;

- Switch off the electrical supply at the isolating switch to the water heater.
- Unplug the power supply cord from the power outlet (power supply cord model only).
- Close the cold water isolation valve at the inlet to the water heater.

OUTLET TEMPERATURE COMPENSATION ADJUSTMENT – RHEEMPLUS

The maximum outlet temperature of a RheemPlus water heater may be adjusted to compensate for temperature losses in the pipe work between the water heater outlet and sanitary fixtures.

⚠ Warning: After adjustment of the temperature limiting valve, the water temperature **MUST NOT** exceed 50°C from the first tap in the hot water pipe work after the water heater used for personal hygiene purposes, such as in a bathroom or ensuite.

To adjust the maximum outlet temperature:

- Ensure the temperature of the water in the water heater is up to the thermostat setting on the water heater.

The temperature of the water can be measured at the temperature pressure relief valve drain discharge point. Do not measure this temperature from a hot tap

- Operate the easing lever on the temperature pressure relief valve and place the thermometer in the flow of water from the relief valve drain line.
- Remove the upper plastic casing and insulation covering the pipe work on the side of the water heater, by removing the three (3) retaining screws, to expose the temperature limiting valve.
- Locate the first hot tap in the hot water pipe work after the water heater used for personal hygiene purposes.
- Turn on the hot tap fully to achieve maximum flow.
- Using a thermometer, measure the temperature of the water from the tap, until the temperature stops increasing.

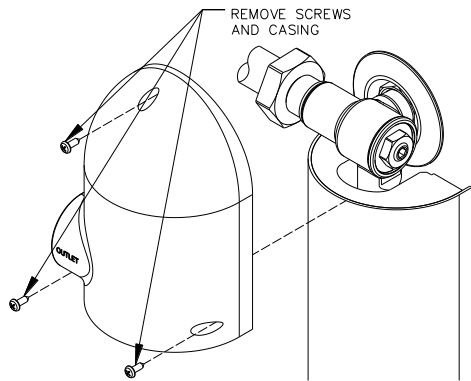

If the water temperature is below 50°C the maximum outlet temperature of the water heater can be adjusted upwards.

- Turn the adjusting knob on the temperature limiting valve counter-clockwise (down away from the water heater), using a 6 mm Allen key.

Turning the adjusting knob counter clockwise (down away from the water heater) increases the outlet water temperature, turning it clockwise (up towards the water heater) decreases the outlet water temperature.

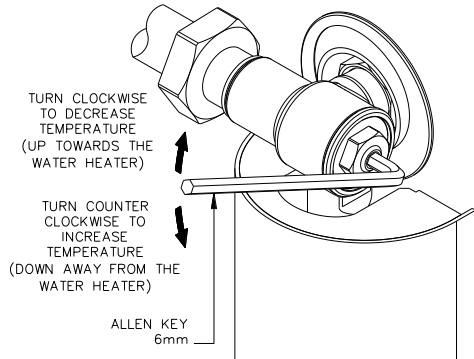

- Repeat the water temperature measurement from the same hot tap.
- Further adjust the temperature limiting valve as required, turning the adjusting knob either counter clockwise (down away from the water heater) or clockwise (up towards the water heater) to increase or decrease the outlet water temperature, until an acceptable water temperature not exceeding 50°C is measured at the same hot tap.

Note: The valve has a stop point for both maximum and minimum outlet water temperature adjustment. The outlet water temperature cannot be increased or decreased beyond these points. It is possible that, depending upon valve tolerances and the pipe work design, 50°C water temperature may not be attainable at the hot tap.

- Turn off the hot tap.
- Replace the insulation and plastic casing to cover the temperature limiting valve and pipe work on the side of the water heater and secure using the three (3) retaining screws.

DRAINING THE WATER HEATER

 **Warning:** Exercise care, as water discharged from the water heater may be of a very high temperature.

To drain the water heater:

- Turn off the water heater (refer to “To Turn Off The Water Heater” on page 39).
- Close all hot water taps.
- Operate the relief valve release lever - do not let the lever snap back or you will damage the valve seat.

Operating the lever will release the pressure in the water heater.

- Undo the union at the cold water inlet to the water heater and attach a hose to the water heater side of the union.

Let the other end of the hose go to a drain.

- Operate the relief valve again.

This will let air into the water heater and allow the water to drain through the hose.

This page is intentionally blank.

This page is intentionally blank.

RHEEM ELECTRIC DOMESTIC MAINS PRESSURE WATER HEATER WARRANTY - AUSTRALIA ONLY

ELECTRIC WATER HEATERS 111, 121, 191, 192 SERIES

1. THE RHEEM WARRANTY – GENERAL

- 1.1 This warranty is given by Rheem Australia Pty Limited ABN 21 098 823 511 of 1 Alan Street, Rydalmere New South Wales.
- 1.2 Rheem offer a trained and qualified national service network who will repair or replace components at the address of the water heater subject to the terms of the Rheem warranty. Rheem Service, in addition can provide preventative maintenance and advice on the operation of your water heater. The Rheem Service contact number is 131031, with Contact Centre personnel available 24 hours, 7 days a week to take your call and if necessary to arrange a service call for during normal working hours Monday to Friday (hours subject to change).
- 1.3 For details about this warranty, you can contact us on 131031 or by email at warrantyenquiry@rheem.com.au (not for service bookings).
- 1.4 The terms of this warranty and what is covered by it are set out in sections 2 and 3 and apply to water heaters manufactured after 1st April 2013.
- 1.5 If a subsequent version of this warranty is published, the terms of that warranty and what is covered by it will apply to water heaters manufactured after the date specified in the subsequent version.

2. TERMS OF THE RHEEM WARRANTY AND EXCLUSIONS TO IT

- 2.1 The decision of whether to repair or replace a faulty component is at Rheem's sole discretion.
- 2.2 If you require a call out and we find that the fault is not covered by the Rheem warranty, you are responsible for our standard call out charge. If you wish to have the relevant component repaired or replaced by Rheem, that service will be at your cost.
- 2.3 Where a failed component or cylinder is replaced under this warranty, the balance of the original warranty period will remain effective. The replacement does not carry a new Rheem warranty.
- 2.4 Where the water heater is installed outside the boundaries of a metropolitan area as defined by Rheem or further than 25 km from either a regional Rheem branch office or an Accredited Rheem Service Agent's office, the cost of transport, insurance and travelling between the nearest branch office or Rheem Accredited Service Agent's office and the installed site shall be the owner's responsibility.
- 2.5 Where the water heater is installed in a position that does not allow safe or ready access, the cost of that access, including the cost of additional materials handling and/or safety equipment, shall be the owner's responsibility. In other words, the cost of dismantling or removing cupboards, doors or walls and the cost of any special equipment to bring the water heater to floor or ground level or to a serviceable position is not covered by this warranty.
- 2.6 This warranty only applies to the original and genuine Rheem water heater in its original installed location and any genuine Rheem replacement parts.

RHEEM ELECTRIC DOMESTIC MAINS PRESSURE WATER HEATER WARRANTY - AUSTRALIA ONLY

ELECTRIC WATER HEATERS 111, 121, 191, 192 SERIES

- 2.7 The Rheem warranty does not cover faults that are a result of:
- a) Accidental damage to the water heater or any component (for example: (i) Acts of God such as floods, storms, fires, lightning strikes and the like; and (ii) third party acts or omissions).
 - b) Misuse or abnormal use of the water heater.
 - c) Installation not in accordance with the Owner's Guide and Installation Instructions or with relevant statutory and local requirements in the State or Territory in which the water heater is installed.
 - d) Connection at any time to a water supply that does not comply with the water supply guidelines as outlined in the Owner's Guide and Installation Instructions.
 - e) Repairs, attempts to repair or modifications to the water heater by a person other than Rheem Service or a Rheem Accredited Service Agent.
 - f) Faulty plumbing or faulty power supply.
 - g) Failure to maintain the water heater in accordance with the Owner's Guide and Installation Instructions.
 - h) Transport damage.
 - i) Fair wear and tear from adverse conditions (for example, corrosion).
 - j) Cosmetic defects.
- 2.8 Subject to any statutory provisions to the contrary, this warranty excludes any and all claims for damage to furniture, carpet, walls, foundations or any other consequential loss either directly or indirectly due to leakage from the water heater, or due to leakage from fittings and/ or pipe work of metal, plastic or other materials caused by water temperature, workmanship or other modes of failure.
- 2.9 If the water heater is not sized to supply the hot water demand in accordance with the guidelines in Rheem's water heater literature, any resultant fault will not be covered by the Rheem warranty.

RHEEM ELECTRIC DOMESTIC MAINS PRESSURE WATER HEATER WARRANTY - AUSTRALIA ONLY

ELECTRIC WATER HEATERS 111, 121, 191, 192 SERIES

3. WHAT IS COVERED BY THE RHEEM WARRANTY FOR THE WATER HEATERS DETAILED IN THIS DOCUMENT

- 3.1 Rheem will repair or replace a faulty component of your water heater if it fails to operate in accordance with its specifications as follows:

What components are covered	The period from the date of installation in which the fault must appear in order to be covered	What coverage you receive
All components	Year 1	Repair and/or replacement of the faulty component, free of charge, including labour.

Rheemglas / RheemPlus models

The cylinder (if the water heater is installed in a single-family domestic dwelling)	Years 2 & 3	Repair and / or replacement of the cylinder, free of charge, including labour.
	Years 4 to 7	Replacement cylinder, free of charge. Installation and repair labour costs are the responsibility of the owner.
The cylinder (if the water heater is <u>not</u> installed in a single-family domestic dwelling)	Years 2 & 3	Replacement cylinder, free of charge. Installation and repair labour costs are the responsibility of the owner.

RHEEM ELECTRIC DOMESTIC MAINS PRESSURE WATER HEATER WARRANTY - AUSTRALIA ONLY

ELECTRIC WATER HEATERS 111, 121, 191, 192 SERIES

4. ENTITLEMENT TO MAKE A CLAIM UNDER THIS WARRANTY

- 4.1 To be entitled to make a claim under this warranty you need to:
- a) Be the owner of the water heater or have consent of the owner to act on their behalf.
 - b) Contact Rheem Service without undue delay after detection of the defect and, in any event, within the applicable warranty period.
- 4.2 You are not entitled to make a claim under this warranty if your water heater:
- a) Does not have its original serial numbers or rating labels.
 - b) Is not installed in Australia.

5. HOW TO MAKE A CLAIM UNDER THIS WARRANTY

- 5.1 If you wish to make a claim under this warranty, you need to:
- a) Contact Rheem on 131031 and provide owner's details, address of the water heater, a contact number and date of installation of the water heater or if that's unavailable, the date of manufacture and serial number (from the rating label on the water heater).
 - b) Rheem will arrange for the water heater to be tested and assessed on-site.
 - c) If Rheem determines that you have a valid warranty claim, Rheem will repair or replace the water heater in accordance with this warranty.
- 5.2 Any expenses incurred in the making of a claim under this warranty will be borne by you.

6. THE AUSTRALIAN CONSUMER LAW

- 6.1 Our goods come with guarantees that cannot be excluded under the Australian Consumer Law. You are entitled to a replacement or refund for a major failure and for compensation for any other reasonably foreseeable loss or damage. You are also entitled to have the goods repaired or replaced if the goods fail to be of acceptable quality and the failure does not amount to a major failure.
- 6.2 The Rheem warranty (set out above) is in addition to any rights and remedies that you may have under the Australian Consumer Law.

RHEEM AUSTRALIA PTY LTD A.B.N. 21 098 823 511 www.rheem.com.au
For Service Telephone 131 031 AUSTRALIA